

Specification

Model: 12V 2/6/10/12/15A

Model No: I-7012

Revision: 1.0

ACDelco 12V Fully Automatic Battery Charger
 For Most DC 12V Rechargeable Lead-acid Batteries

- Innovative Technology Powered
- Charge Rate: 2/6/10/12/15 Amp
- Over-charge and overheat protections
- Short-circuit protection
- Spark-free design
- Battery maintenance
- Alternator check
- Auto wake up to maintain battery level at all time
- Built-in battery tester

3-Stage Pulse Charging + Battery Maintenance
 Perform battery maintenance and charging at the same time!



LOW RATE CHARGE
2 AMP

MED / FAST RATE CHARGE
6/10/12/15 AMP



Table of Contents

1 INPUT REQUIREMENTS

1.1 INPUT VOLTAGE

1.2 INPUT FREQUENCY

1.3 INPUT CURRENT

1.4 INPUT PROTECTION

1.4.1 INPUT CURRENT PROTECTION

1.5 EFFICIENCY

2 OUTPUT REQUIREMENTS

2.1 OUTPUT POWER

2.2 OUTPUT VOLTAGE AND CURRENT

2.3 REFERENCE CHARGING CURVE

2.4 OVER POWER PROTECTION

2.5 SHORT CIRCUIT POTECTION

2.6 FAN SPEED CONTROL BY THERMAL SENSOR

2.7 A MAINTENACE PULSE CHARGE

2.8 INSUFFIEIENT POWER

3 ENVIRONMENT

3.1 OPERATING / STORAGE TEMPERATURE

3.2 HUMIDITY

3.3 SHOCK AND VIBRATION

3.3.1 SHOCK NON-OPERATION

3.3.2 VIBRATION

3.4 CALCULATED MEAN TIME BETWEEN FAILURES (MTBF)

4 SAFETY

4.1 DIELECTRIC VLOTAGE WITHSTAND (HI-POT)

4.2 PRODUCT DROP TEST

4.3 BALL IMPACT TEST

4.4 STRAIN RELIEF TEST

4.5 CLAMP ATTACHMENT SECURITY

4.6 HANDLE ATTACHMENT SECURITY

4.7 CLAMP RETENTION

4.8 CORROSION RESISTANCE

4.9 SWITCH OPERABILITY

5 EMC SPECIFICATION

5.1 EMI REQUIREMENTS

6 MECHANICAL

6.1 DIMENSION

6.1.1 PRODUCT

6.1.2 CLAMP

6.2 MATERIAL

6.2.1 ENCLOSURE

6.2.2 CLAMP

6.2.3 TACT SWITCH

6.3 INPUT CONNECTOR AND OUTPUT CABLE

6.3.1 INPUT CONNECTOR/AC CORD

6.3.2 OUTPUT CABLE

1 INPUT REQUIREMENTS

1.1 INPUT VOLTAGE

The power supply must operate on a sinusoidal input voltage defined in table 1.

Input Range	Minimum	Nominal	Maximum	Unit
180V-264V	180	230	264	Vac

Table 1 - Input Voltage Range

1.2 INPUT FREQUENCY

The power supply shall operate within specification 50~60 \pm 3 Hz.

1.3 INPUT CURRENT

Maximum steady state input current shall not exceed 2 A for any line voltage specified in table 2.

1.4 INPUT PROTECTION

1.4.1 INPUT CURRENT PROTECTION

A fuse with rating of 3.15 A / 250 V(Time Lag) shall be installed on the input line side near the input connector to provided protection to the power supply.

1.5 EFFICIENCY

The power supply efficiency shall not be less than 80% at the maximum load of section 2.2(230/50Hz)

2 OUTPUT REQUIREMENTS

2.1 OUTPUT POWER

Unit total output power, under steady state conditions, shall not exceed 200 W.

2.2 OUTPUT VOLTAGE AND CURRENT

	Output Voltage	Voltage Range		Current Range
		Lower Limit	Upper Limit	
1	+15V	14.5	15.0	10A
		13.5	14.3	15A

Table 2 - Output Voltage and Current

Note: 1). The output voltage should be measured at output connector terminals.

2.3 REFERENCE CHARGING CURVE

Charging Voltage

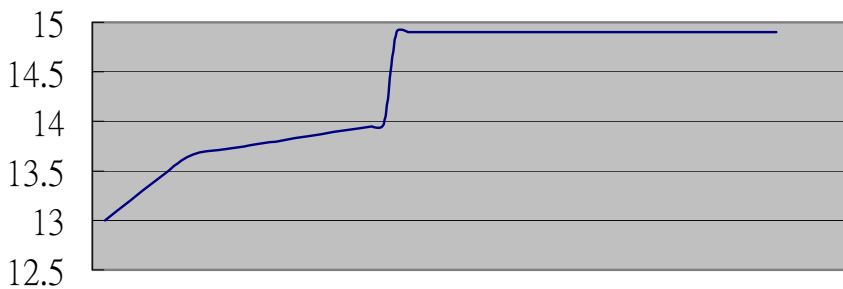

2.4 OVER POWER PROTECTION

Over power protection shall operate at 110% Max. of rated power defined in section 2.2 at table-1 line input conditions.

2.5 SHORT CIRCUIT POTECTION

Power supply shall have self-limiting protection to protect against short circuit or overload conditions. No damage to the supply shall result from intermittent short circuit condition.

2.6 FAN SPEED CONTROL BY THERMALSENSOR

Stop: 0°C to 30°C

Mid rate: 30°C to 60°C

Max rate: >60°C

2.7 MAINTENANCE PULSE CHARGE

Current rate: 800mA Max. Charging Voltage: 14V +-10%

2.8 INSUFFICIENT POWER

Voltage: under 7V

3 ENVIRONMENT

3.1 OPERATING / STORAGE TEMPERATURE

Operation: 0 to 40°C.

Storage: -20 to 80°C

3.2 HUMIDITY

Operation: 10% to 90% RH, non-condensation.

Storage : 5% to 95% RH, including condensation.

3.3 SHOCK AND VIBRATION

3.3.1 SHOCK NON-OPERATION

The unit shall be subjected to a series of six(6) shocks, one(1) on each side, Top and bottom. Each shock shall consist of a 50G half sine wave pulse with a velocity change of 167 in/sec.

3.3.2 VIBRATION

Operating: 10-250Hz, 0.25Gs peak to peak, 3 axes, 15 min sweep.

Non-Operation: 10-300Hz, 2.0Gs peak to peak, 3 axes, 15 min sweep.

3.5 CALCULATED MEAN TIME BETWEEN FAILURES (MTBF)

Power supply shall have a calculated MTBF of greater than 30,000 hours, calculated utilizing MIL-HDBK-217F with the following assumptions:

Input voltage: 230Vac / 50Hz

Output load: Rated full load

Ambient temperature: 25 degrees C

4 SAFETY

Unless otherwise specified, the supply is designed to meet BS approved addition and/or equivalent safety standards for use in Battery Charger Equipment. Specific agency certifications will be applied at customer's request and cost.

UK: BS APPROVED

Note: Leakage current shall be less than 0.50 mA at input voltage of 230Vac / 50Hz.

4.1 DIELECTRIC VLOTAGE WITHSTAND (HI-POT)

The power supply shall withstand following Hi-pot test without breakdown.

4242 Vdc line to ground for 1 minute.

4242 Vdc input to output for 1 minute.

Note: Time duration may reduce to 1 second on production.

4.2 PRODUCT DROP TEST

Number of Drops : 3 times.

Height: 90 cm

Floor surface: Concrete Floor

Judging Criteria : To withstand Hi-Pot Test , and without electrical breakdown.

4.3 BALL IMPACT TEST

Ball Spec. : Steel Ball , Diameter=51.8 m/m , Weight=535 gw

Height of Drop : 90 cm

Number of Drops : 3 times.

Judging Criteria : To withstand Hi-Pot Test , and without electrical breakdown.

4.4 STRAIN RELIEF TEST

The strain relief withstand a pull force of 35 lb applied for 1 minute in a direction most likely to cause damage.

4.5 CLAMP ATTACHMENT SECURITY

Conductor is securely attached to clamp , conductor to clamp connection withstands a 35 lb tensile load without separation.

4.6 HANDLE ATTACHMENT SECURITY

Handle to enclosure connection withstands 4 times weight of the charger with separation.

4.7 CLAMP RETENTION

Clamp provides good terminal gripping capability. Clamp does not become dislodged from 5/8 inch diameter lead terminal post when pulled with a force of 10 lb at 90 degrees to the axis of the clamp.

4.8 CORROSION RESISTANCE

Clamp demonstrates no excessive surface corrosion after 12 hours exposure to 100% humidity 100°F.

4.9 SWITCH OPERABILITY

Withstands 200 ON / OFF cycles (energized) with no evidence of electrical or mechanical malfunction.

5 EMC SPECIFICATION

5.1 EMI REQUIREMENTS

- To comply with Low Voltage Directive 73/23/EEC
- To comply with EMC Directive 89/336/EEC

6 MECHANICAL

6.1 DIMENSION

6.1.1 PRODUCT

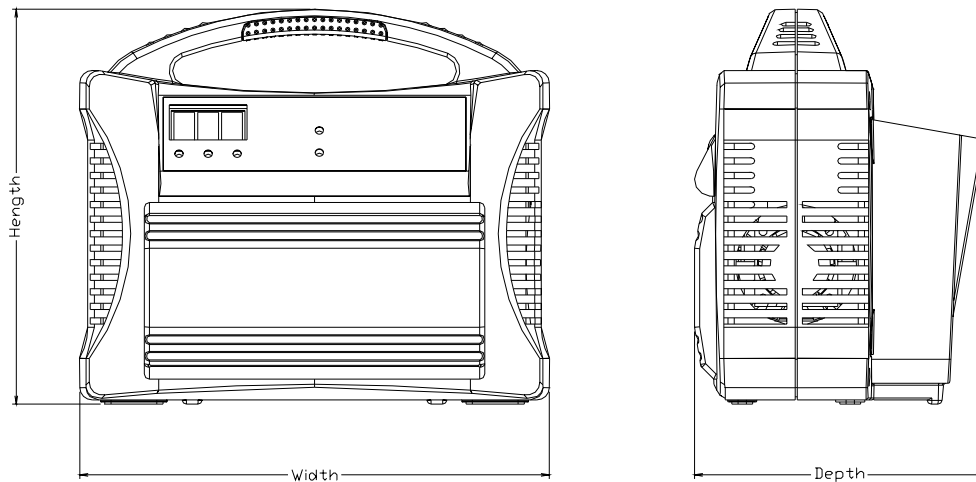

Height = 190 m/m

Width = 226 m/m

Depth=140 m/m

Weight=1825 gw

6.1.2 CLAMP

Length = 92.7 m/m

Width = 56 m/m

Jaw Length =35 m/m

Jaw Width =18 m/m

Weight =40 gw

6.2 MATERIAL

6.2.1 ENCLOSURE

Housing – Plastic ABS UL 94-V0

Bind Cable – Silicon Rubber

Foot Pad – NBR Rubber

6.2.2 CLAMP

Clamp – SPCC , Nickel-plate

Clamp Spring – SUS-4

Handle – PU

6.2.3 TACT SWITCH

Operating Force – 160 ± 50 gf

Switch Life – 100,000 strokes

6.3 INPUT CONNECTOR AND OUTPUT CABLE

6.3.1 INPUT CONNECTOR

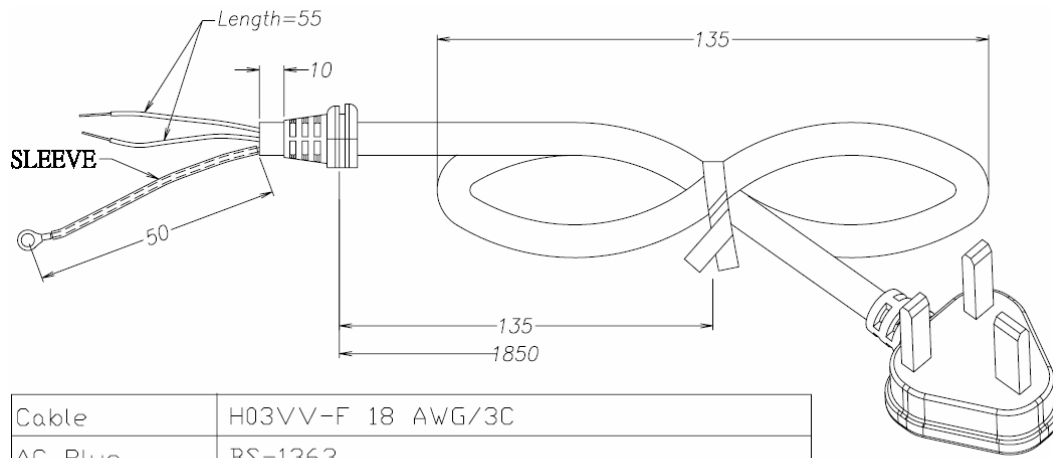

Cable	H03VV-F 18 AWG/3C
AC Plug	BS-1363
Terminal	Ø4.0

6.3.2 OUTPUT CABLE

The output cable shall be 6 ft mm long, A1015 12 AWGX2C wire, and Black/RED in color.

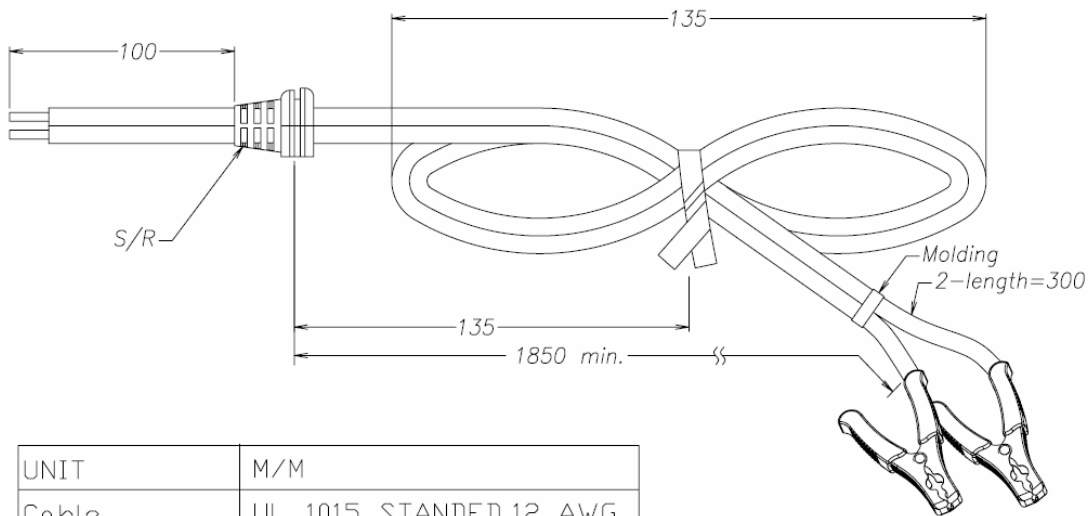

UNIT	M/M
Cable	UL 1015 STANDED,12 AWG

